

## LNA for W-CDMA (UMTS) Features Gain Step

*The MAX2645 Silicon Germanium (SiGe) Low-Noise Amplifier (LNA) features a 25dB gain step, shutdown mode, and adjustable IP3. The LNA has been optimized for WCDMA applications in the UMTS band (2110MHz - 2170MHz). The MAX2645 features 19.5dB of gain, 1.9dB noise figure, and an IIP3 of +2.5dBm in the high gain mode. With a typical operating supply voltage of +3.3V, the supply current is a low 8.9mA in the high gain mode, 2.7mA in the low gain mode, and typically 0.1µA in the shutdown mode.*

Table 1 summarizes the performance of the MAX2645 operating at 2.14GHz. The schematic used to optimize the MAX2645 for 2.14GHz is represented in Figure 1. Figures 2 through 6 demonstrate the performance of the LNA in both high gain and low gain modes from 2.1GHz to 2.2GHz. Tuning capacitors are common Murata 0402 GRP1555C (GRM36) series, and the tuning inductors are Murata 0402 printed LQP10A series. For further information, consult the MAX2645 SiGe LNA datasheet and EV kit datasheet.

**Table 1. MAX2645 SiGe LNA Performance at 2.14GHz**

Mode	I <sub>CC</sub> (mA)	Gain (dB)	NF (dB)	IIP3 (dBm)	S11 (dB)	S22 (dB)
High Gain	8.9	+19.5	1.87	+2.5	-9.5	-14.7
Low Gain	2.7	-6.8	13.86	+16.3	-8.3	-8.0

Note: V<sub>CC</sub> = +3.3V, R<sub>BIAS</sub> = 20kΩ

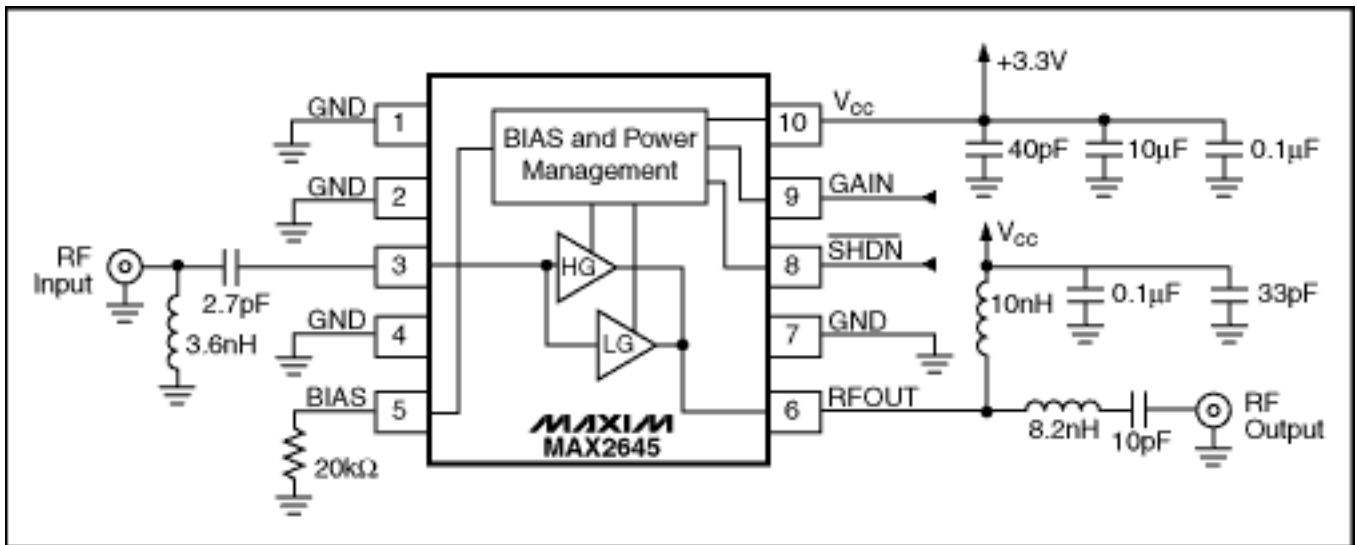

Figure 1. MAX2645 SiGe LNA Operating Circuit Optimized for 2.14GHz.

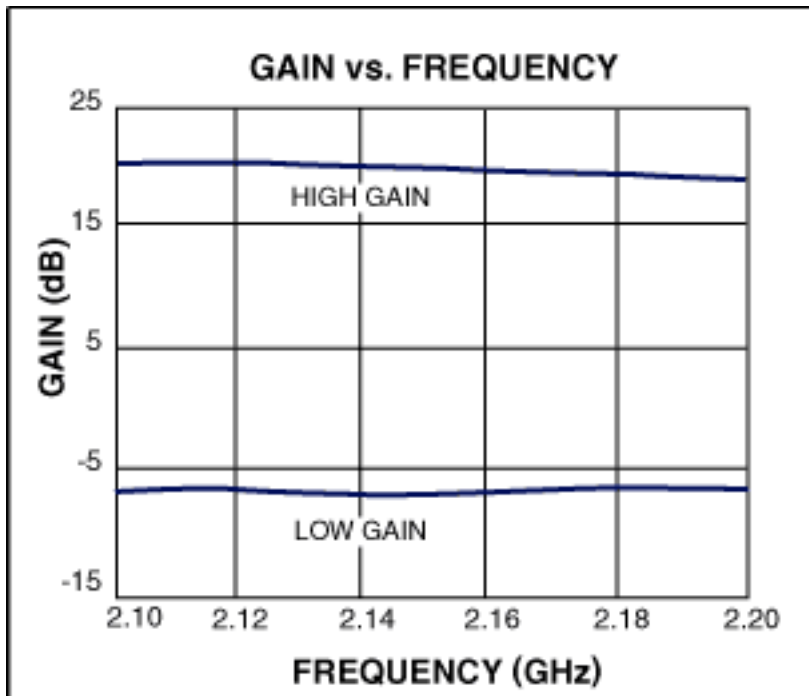

Figure 2. MAX2645 Gain vs. Frequency Plot.

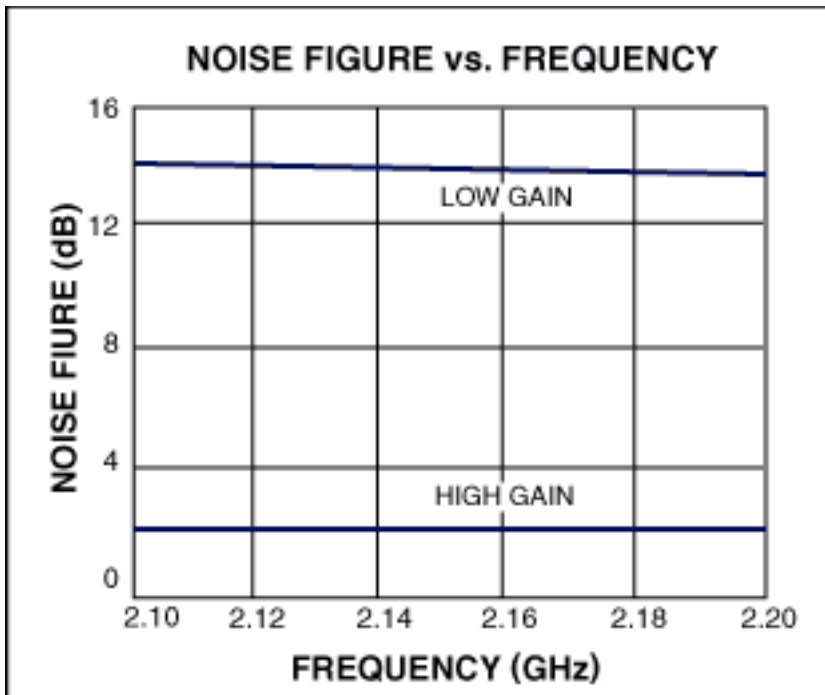

Figure 3. MAX2645 Noise Figure vs. Frequency Plot.

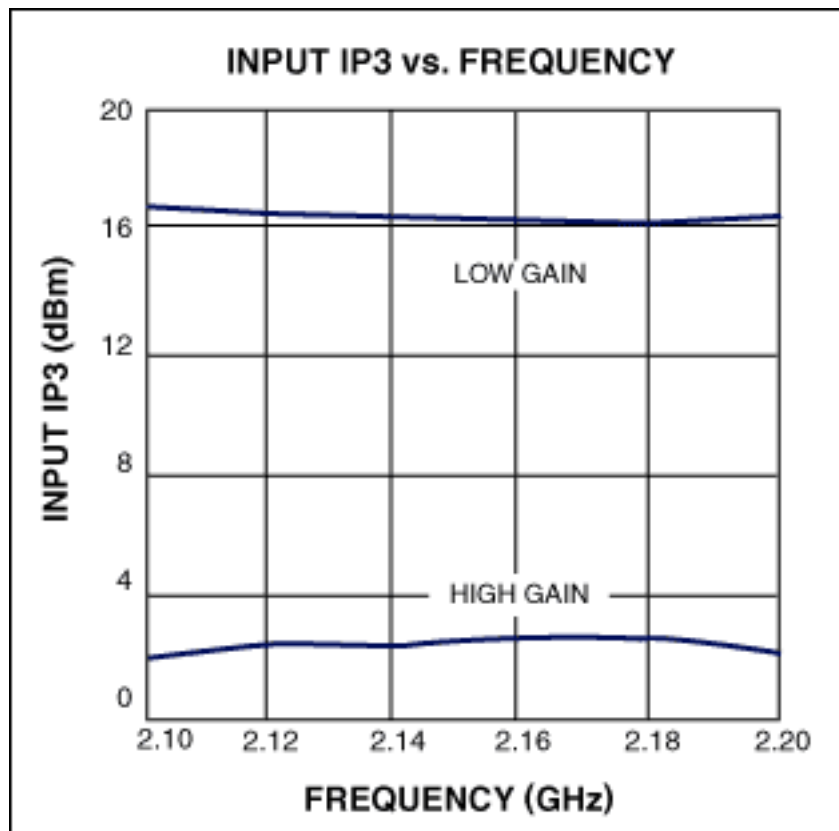

Figure 4. MAX2645 Input IP3 vs. Frequency Plot.

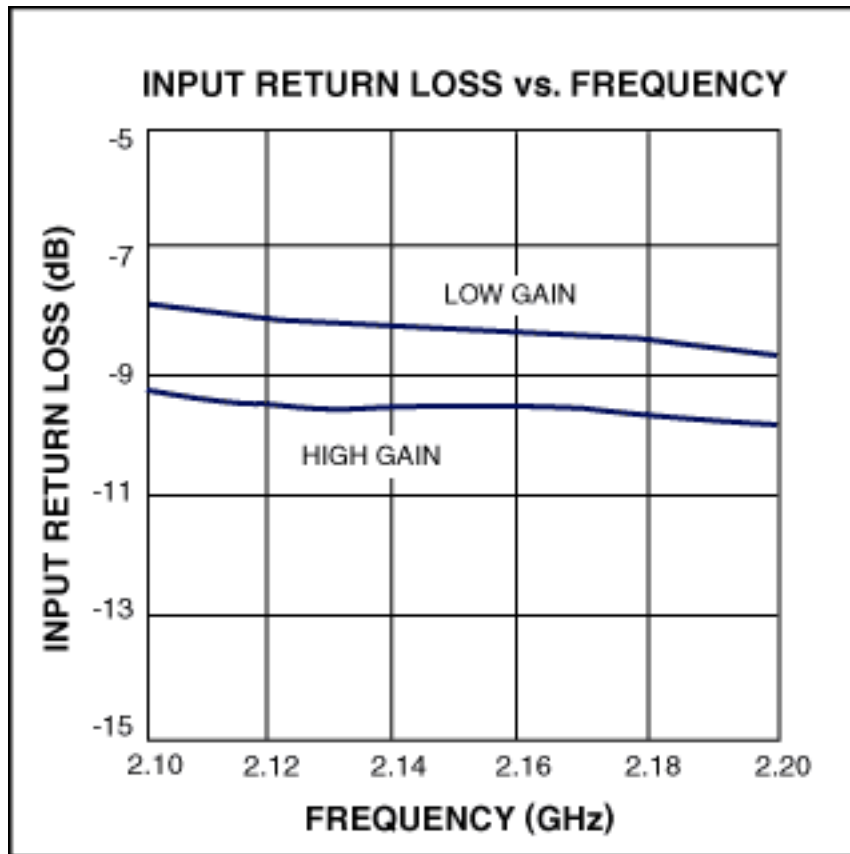
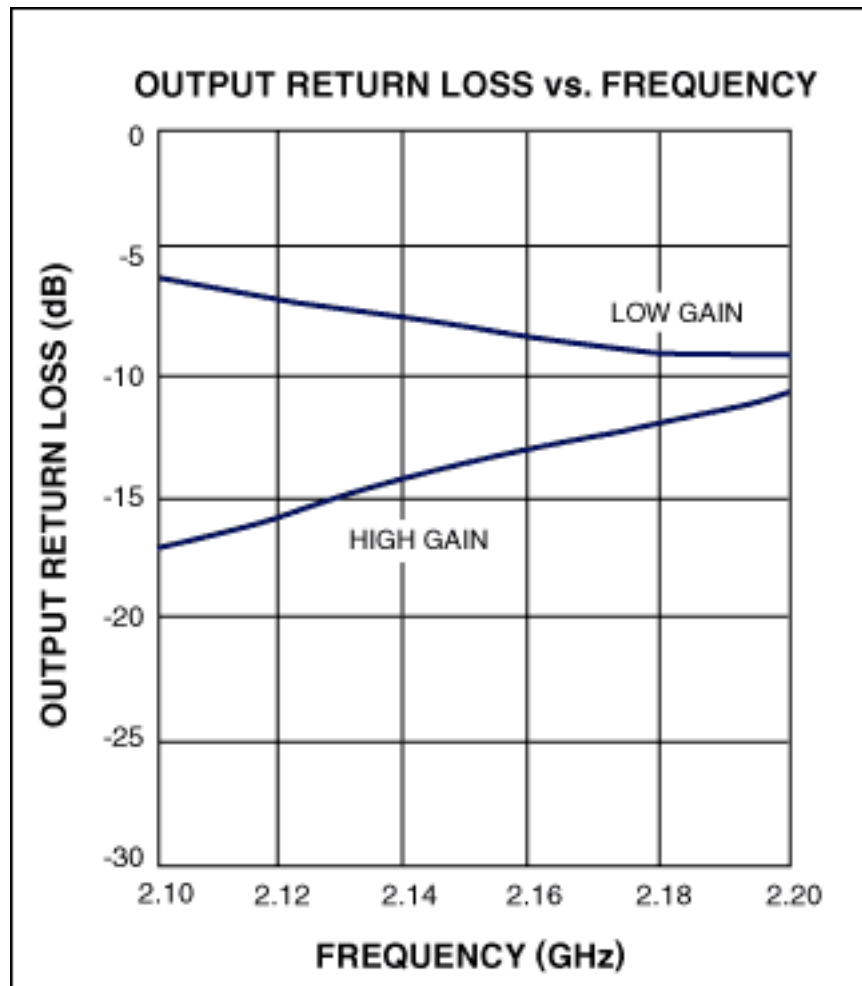

Figure 5. MAX2645 Input Return Loss vs. Frequency Plot.



*Figure 6. MAX2645 Output Return Loss vs. Frequency Plot.*

### **More Information**

max2645: [QuickView](#) -- [Full \(PDF\) Data Sheet](#) -- [Free Samples](#)